

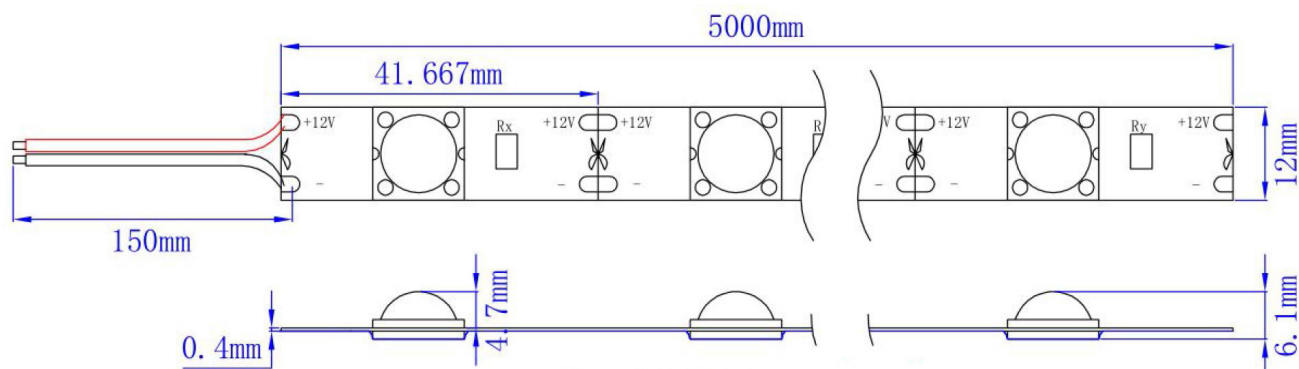

**3** 3 YEARS WARRANTY



**DC12V-3030**

<b>3030 SMD</b>
FSIL.3030.1264.2412
FORM-025
<b>DC12V</b>
<b>1.25A</b>
<b>15.0W/M</b>
<b>3030-1W</b>
<b>24 PCS/M</b>
<b>12000K</b>
<b>&gt;70</b>
<b>165~170°</b>
<b>1350Lm</b>
<b>12mm</b>
<b>IP65</b>
<b>150mm</b>
<b>30000H</b>
<b>CE-EMC、CE-LVD、FCC、RoHS</b>
<b>0.205Kg</b>
<b>L370*W250*H250mm</b>